

Fox Thermal Flow Meter Troubleshooting Guide

Introduction

This document is used to address troubleshooting, installation, and calibration issues on all Fox Thermal flow meters. Your assistance using the following procedure is appreciated and should facilitate faster service:

- Answer the required questions for all models in Step 1.
- Answer model-specific questions in Step 2.
- Contact Fox Thermal’s Service department with your answers from Steps 1 and 2.
 - Fox Thermal Main Phone Line: 831-384-4300
 - Service Department Email: service@foxthermal.com

All Models

Step 1: Required Information of All Model Types

1. What is the serial number and model number of the flow meter?
2. Please describe the problem(s) in detail.
3. Approximately when did the problem start? Did the flow meter ever work properly or has the problem existed since the initial installation?
4. Have any of the flow meter settings been changed since you received the meter from Fox?
5. Does the meter installation meet these up and downstream straight pipe requirements?

- For insertion-type meters, Fox recommends a minimum of 15 straight-pipe diameters upstream of the flow meter and 10 straight-pipe diameters downstream.

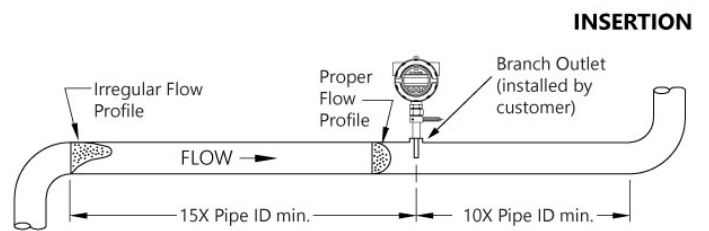

- For inline-type meters, Fox recommends a minimum of 8 straight-pipe diameters upstream of the flow meter and 4 straight-pipe diameters downstream.

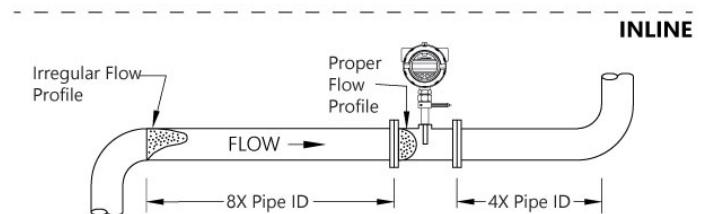

- If the FC20 flow conditioner is used with an insertion-type meter, Fox recommends a minimum of 5 straight-pipe diameters upstream of the flow conditioner, exactly 2 straight-pipe diameters upstream (between the flow conditioner and the probe), and a minimum of 5 straight-pipe diameters downstream of the probe.

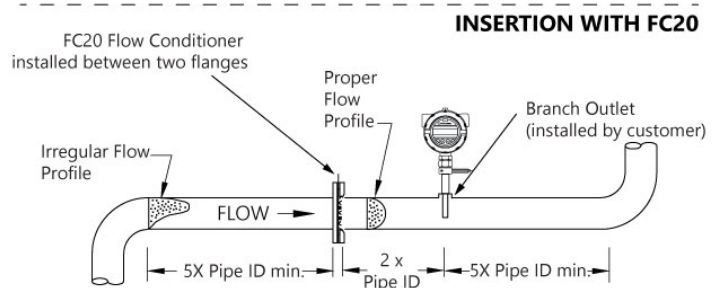

6. What flow rate is displayed on the flow meter? What is the expected flow rate? What type of device or measurement is the Fox Thermal flow meter’s flow measurement being compared to? Please provide specific data.
7. What is the inside diameter (ID) of the pipe? Is the actual pipe ID the same as listed on the Calibration Certificate? If not, does the meter’s programmed pipe ID match the actual pipe ID?
8. Has there been any change in meter location or pipe configuration?

Step 2: Model-Specific Information

Use the “Find Your Model” table below to find the page number for the appropriate model in this document, answer the model-specific questions in Sections A and B, then contact Fox Thermal’s service department with your answers from Step 1 and 2.

Find Your Model

Model FT1.....	3
Model FT2A	5
Model FT3.....	8
Model FT4A	12
Model FT4X.....	14

Model FT1

Section A: FT1 Troubleshooting

Please refer to the troubleshooting section of the FT1 Manual. There is a link to the Fox model FT1 Instruction Manual located on the "Downloads" tab of the FT1 product webpage or here for quick reference:

<https://www.foxthermal.com/products/pdf/ft1/ft1-manual.pdf>

1. Perform a CAL-V™ test. Record the values and Pass/Fail result.
2. If applicable, please provide all alarm codes shown on the display (shown by scrolling to Display Screen #3). You can also read the alarms on a PC using Fox's FT1 View™ software. Please visit the following URL to download FT1 View™:

<https://www.foxthermal.com/products/pdf/ft1/ft1-view-setup.exe>
3. Test/Check the LED status (Heartbeat) light of the FT1. Is the LED (green) blinking once per second?
 - The LED lights can be viewed by unscrewing the front cap to reveal the display and configuration panel. Then unscrew the two phillips screws holding the display. Swing the display panel open to reveal the wiring and LED lights (as shown in Figure below).
 - The Heartbeat LED blinks fast when the FT1 is powered up, and blinks about once a second when the FT1 operates normally. The Transmit and Receive LEDs blink when messages are sent and received through serial communication. The Receive LED may be illuminated if the FT1 has HART communication and the 4-20mA output is not connected.

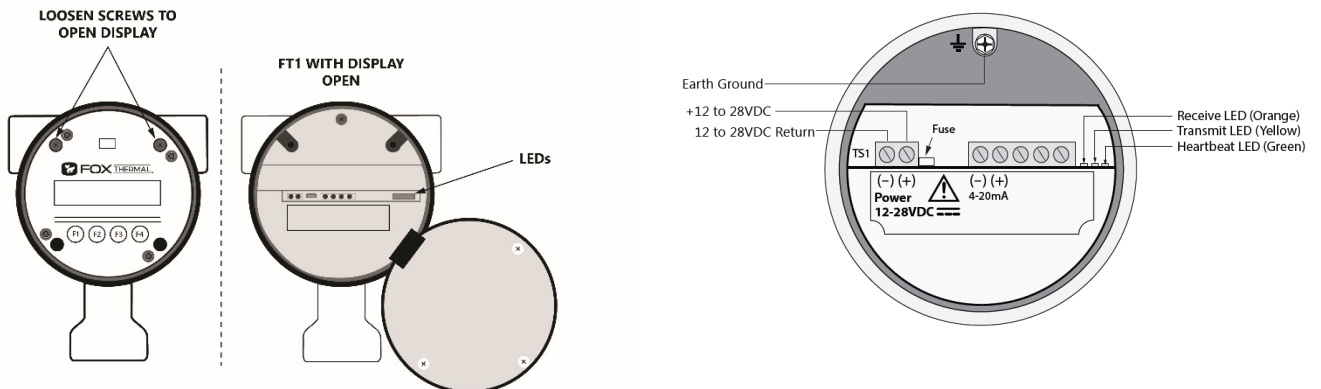

4. What is the measured input power to the flow meter at terminal TS1 pins 1 (+) and 2 (-)?
 - Acceptable voltages: 12 to 24VDC (10 to 30VDC full input power range)
5. Test/Check the fuse in the FT1.
 - With the power off, take a resistance measurement across the fuse to ensure it is a short circuit.

Section B: FT1 Measurement Accuracy and Calibration:

6. Are the readings taken from the flow meter display or from a different source (PLC, DCS, etc)? The 4mA and 20mA scaling in the PLC or DCS must match the flow meter's settings. If you are using the 4-20mA output, also confirm that the measurement unit (SCFM, KG/HR, NM3H, etc.) in the Fox meter is the same as in your PLC/DCS.
7. If measuring a gas mixture, ensure the gas mixture equals 100%. If not, what gas are you currently measuring? Does the Gas-SelectX® setting in the FT1 closely match the composition of the gas being measured?
8. Check insertion depth, is the end of the sensor window 0.73" (18.5 mm) past the center line of the pipe?

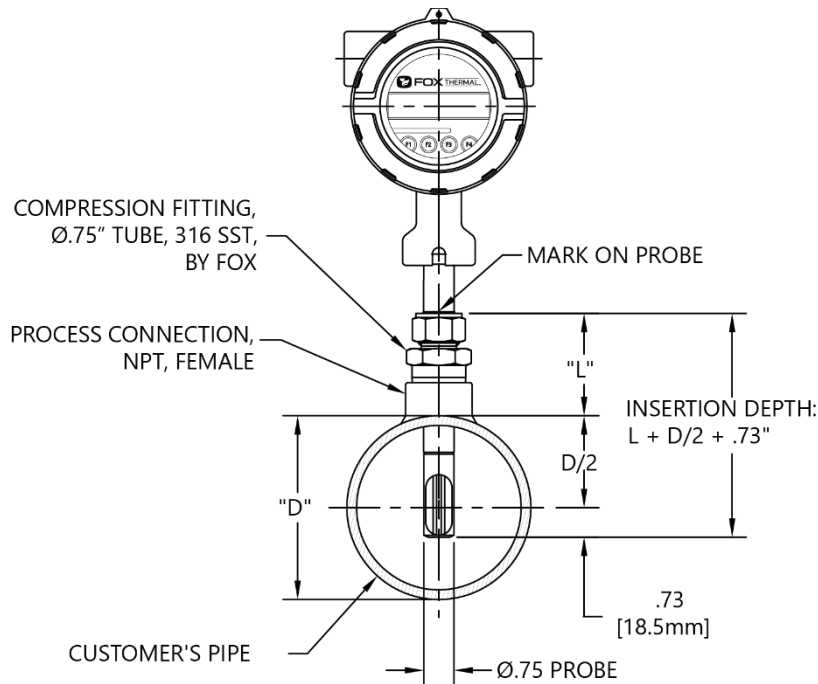

9. Check the direction of flow:
 - Is the flow direction indicator pointed in the direction of flow?
 - Is the flow direction indicator aligned with the pipe ± 2 degrees?
 - For inline type flow meters: Is the arrow on the flow body pointing in the direction of flow?

Model FT2A

Section A: FT2A Troubleshooting

Please refer to the troubleshooting section of the FT2A Manual. There is a link to the Fox model FT2A Instruction Manual located on the "Downloads" tab of the FT2A product webpage or here for quick reference:

<https://www.foxthermal.com/products/pdf/ft2a/ft2a-manual.pdf>

1. If applicable, please provide all alarm codes shown on the display (shown by scrolling to Display Screen #3). You can also read the alarms on a PC using Fox's FT2A View™ software. Please visit the following URL to download FT2A View™:
<https://www.foxthermal.com/products/pdf/ft2a/ft2a-view-setup.exe>
2. Open the display by unscrewing the four phillips screws in the corners of the display of the FT2A. What is the measured input power to the flow meter at the correct terminal for the input power type?
 - Acceptable voltages, terminal locations:
 - DC powered: 24VDC ($\pm 10\%$), terminal TS1 pins 1 (+) and 2 (-)
 - AC powered: 100 to 240VAC, terminal TS7 pins 1 and 2
3. Test/Check the fuse in the FT2A.
 - With the power off, take a resistance measurement across the fuse to ensure it is a short circuit.
 - Acceptable resistance: <1 ohm.
4. Test/Check the LED status (Heartbeat) light of the FT2A. Is the LP1 LED (green) blinking once per second?
 - The LP1 status LED (green) light can be viewed by opening the enclosure.
 - Is the Power LP4 LED (orange) emitting a steady orange light?
5. For remote sensor configurations (see images on next page):
 - If the sensor is remote from the electronics, please provide the length and gauge of the wire/cable connecting the sensor junction box to the electronics housing.
 - The serial number on the electronics housing must match the serial number on the probe/sensor assembly. It is a common mistake to mix the serial numbers when multiple meters with remote electronics are ordered. Please confirm the probe serial number is the same as on the electronics housing.
 - Carefully check for proper wire terminations at the sensor junction box and at the electronics housing.

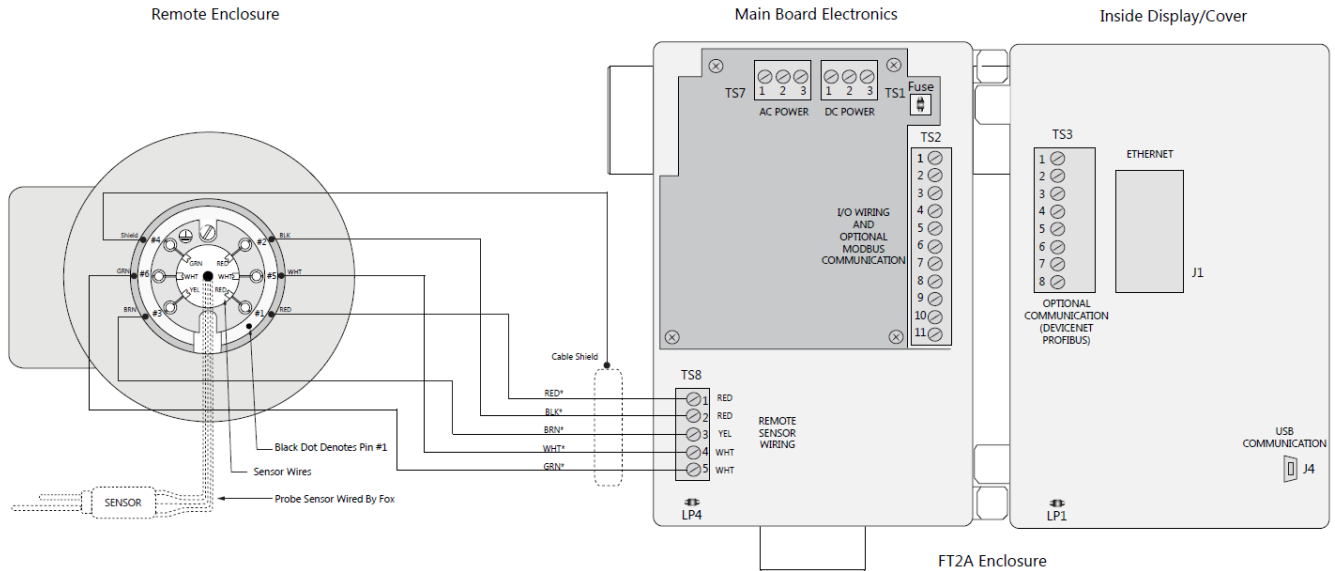

Electronics Enclosure Terminal numbers	Extension Cable Wire Color	Remote Enclosure Terminal Numbers	Sensor Wire Color
1	Red	1	Red
2	Black	2	Red
3	Brown	3	Yellow
No Connection	Shield	4	Green
4	White	5	White
5	Green	6	White

6. Confirm the sensor resistances are correct.

- Turn off power to meter and disconnect sensor wires from TS8 (the sensor termination terminal strip located at the bottom of FT2A main board) before taking measurements.
- Sensor wiring: White to White wires = 200 to 225 ohms, Red to Red = 0.1 ohms, Red to Yellow = 9 to 10 ohms.

Section B: FT2A Measurement Accuracy and Calibration

7. Close the display. Are the readings taken from the flow meter display or from a different source (PLC, DCS, etc)? The 4mA and 20mA scaling in the PLC or DCS must match the flow meter’s settings. If you are using the 4-20mA output, also confirm that the measurement unit (SCFM, KG/HR, NM3H, etc.) in the Fox meter is the same as in your PLC/DCS.
8. Is the composition of the gas you are measuring the same as is shown on the flow meter calibration certificate?
9. Check insertion depth, is the end of the sensor window 0.87" (22.098 mm) past the center line of the pipe (see image on next page)?

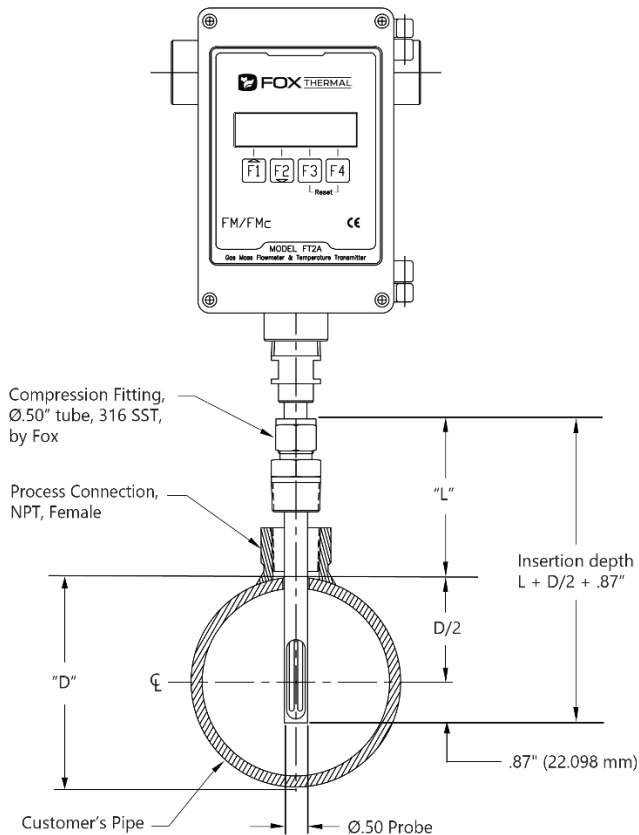

10. Check the direction of flow:

- Ensure the sensor elements are aligned correctly with the flow (± 2 degrees). Note differences between equal and unequal sensor types.

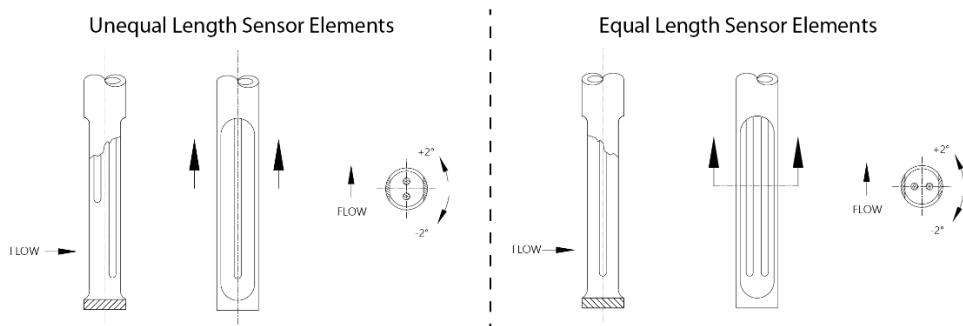

- Insertion type flow meters: Is the arrow on the flow meter probe pointing in the direction of flow?
- Inline type flow meters: An inline meter will have the flow direction arrow on both the probe and flow body. Are both arrows pointing in the direction of flow?

11. What is the CSV voltage?

- Press the F1 & F2 keys at the same time in normal mode to access the engineering displays. Display #10 will have the CSV value. Compare this value to the meter's calibration certificate.

Model FT3

Section A: FT3 Troubleshooting

Please refer to the troubleshooting section of the FT3 Manual. There is a link to the Fox model FT3 Instruction Manual located on the "Downloads" tab of the FT3 product webpage or here for quick reference:

<https://www.foxthermal.com/products/pdf/ft3/ft3-manual.pdf>

1. Perform a Zero CAL-CHECK® test. Record the values and Pass/Fail results.
2. Perform a CAL-V™ test. Record the values and Pass/Fail results.
3. If applicable, please provide all alarm codes shown on the display (shown by scrolling to Display Screen #3). You can also read the alarms on a PC using Fox's FT3 View™ software. Please visit the following URL to download FT3 View™:

<https://www.foxthermal.com/products/pdf/ft3/ft3-view-setup.exe>

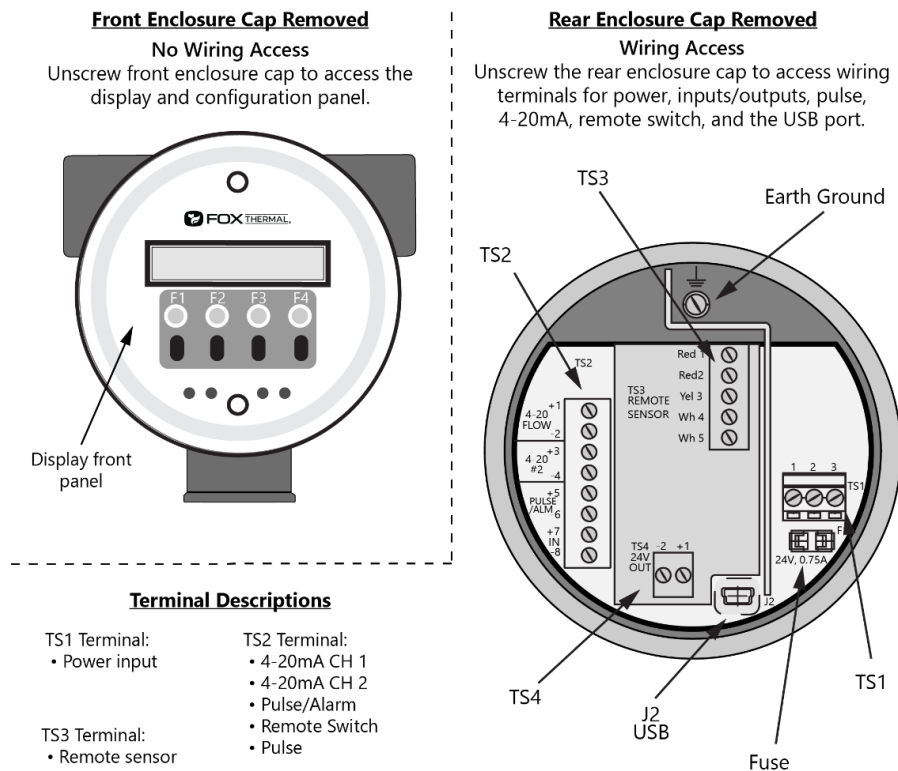

4. What is the measured input power to the flow meter at terminal TS1 pins 1 (+) and 2 (-)?
 - Acceptable voltages:
 - DC powered: 24VDC ($\pm 10\%$)
 - AC powered: 100 to 240VAC
5. Test/Check the fuse in the FT3.
 - With the power off, take a resistance measurement across the fuse to ensure it is a short circuit.
 - Acceptable resistance: <1 ohm.

6. Test/Check the LED status (Heartbeat) light of the FT3. Is the LED (green) blinking once per second?
 - The LED lights can be viewed by unscrewing the front cap to reveal the display and configuration panel. The LED status lights are visible behind the Display panel. To get a better view, remove the display panel by unscrewing the two screws on the display panel as shown below.
 - LED indicator LP3 cycles on and off to indicate that the FT3 is operating.

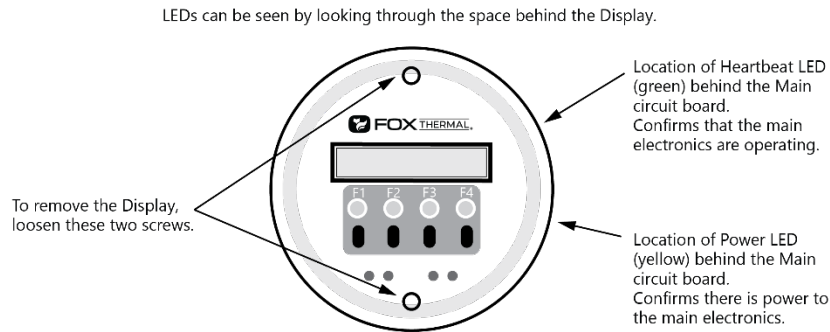

- The Modbus and HART LEDs on the FT3 are visible by removing the rear enclosure cap to expose the I/O terminal board.

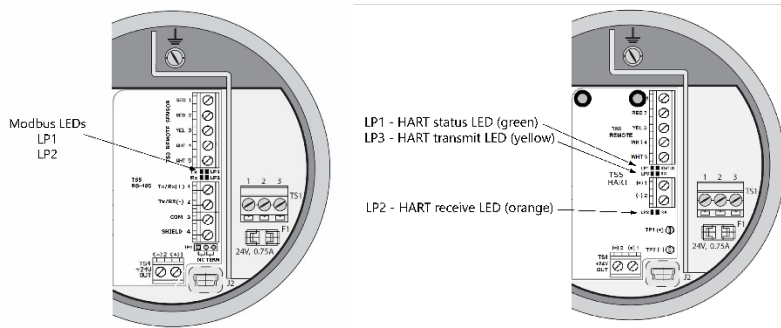

- Modbus: LED indicator LP2 blinks when communication signals are received and LP1 blinks when communication signals are transmitted.
 - HART: LED status indicator LP1 blinks to indicate that the HART circuit is operation. LP2 blinks when communication signals are received and LP3 blinks when communication signals are transmitted (if nothing is connected to the 4-20mA output, LP3 will be on continuously).
7. What is the CSV voltage? This information can be taken from the Engineering Display: press F1 and F2 at the same time and release (see "Engineering Displays" in the FT3 Manual). The screen will change to display #10. The flow rate will be on the upper line and the CSV voltage will be on the lower line of the display. Record the CSV and flow rate then press F4 to exit the Engineering Displays.
 8. For remote sensor configurations:
 - If the sensor is remote from the electronics, please provide the length and gauge of the wire/cable connecting the sensor junction box to the electronics housing.
 - The serial number on the electronics housing must match the serial number on the probe/sensor assembly. It is a common mistake to mix the serial numbers when multiple meters with remote electronics are ordered. Please confirm the probe serial number is the same as on the electronics housing.

- Carefully check for proper wire terminations at the sensor junction box and at the electronics housing.

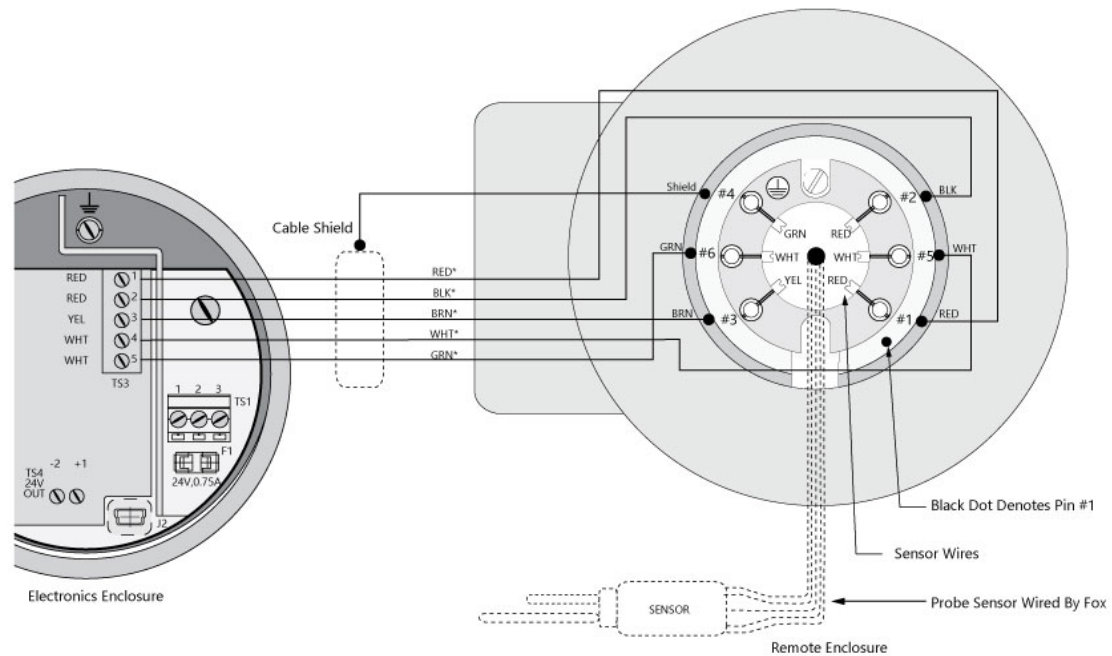

Electronics Enclosure Terminal numbers	Extension Cable Wire Color	Remote Enclosure Terminal Numbers	Sensor Wire Color
1	Red	1	Red
2	Black	2	Red
3	Brown	3	Yellow
No Connection	Shield	4	Green
4	White	5	White
5	Green	6	White

- If advised by a Fox technical representative, please confirm the following sensor resistances are correct.
 - For a non-remote meter, remove the display and disconnect sensor wires from TS-8 (the sensor termination terminal strip located at the bottom of FT3 board # 104036) before taking measurements: White to White wires= 200 to 225 ohms, Red to Red = .1 ohms, Red to Yellow = 9 to 10 ohms. Record the results.
 - For remote mounted electronics disconnect the wire from the remote sensor connector located at the rear of the electronics enclosure

Section B: FT3 Measurement Accuracy and Calibration

- Are the readings taken from the flow meter display or from a different source (PLC, DCS, etc)? The 4mA and 20mA scaling in the PLC or DCS must match the flow meter's settings. If you are using the 4-20mA output, also confirm that the measurement unit (SCFM, KG/HR, NM3H, etc.) in the Fox meter is the same as in your PLC/DCS.
- Is the gas composition you are measuring the same as is shown on the flow meter calibration certificate?
- Check insertion depth, is the end of the sensor window 0.87" (22.098 mm) past the center line of the pipe?

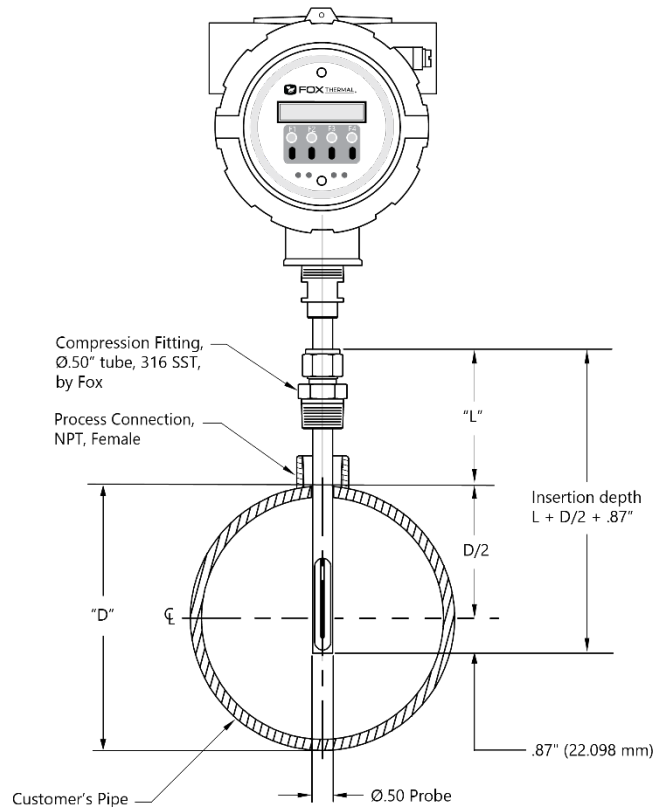

13. Check the direction of flow:

- Ensure the sensor elements are aligned correctly with the flow (± 2 degrees).

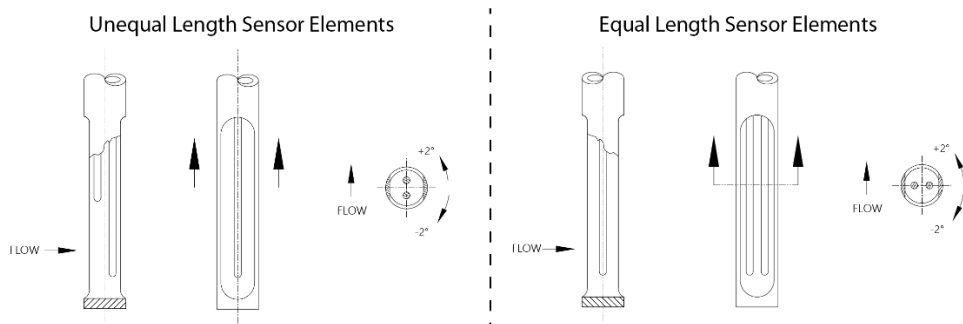

- Insertion type flow meters: Is the arrow on the flow meter probe pointing in the direction of flow?
- Inline type flow meters: An inline meter will have the flow direction arrow on both the probe and flow body. Are both arrows pointing in the direction of flow?

Model FT4A

Section A: FT4A Troubleshooting

Please refer to the troubleshooting section of the FT4A Manual. There is a link to the Fox model FT4A Instruction Manual located on the "Downloads" tab of the FT4A product webpage or here for quick reference:

<https://www.foxthermal.com/products/pdf/ft4a/ft4a-manual.pdf>

1. Perform a CAL-V™ test. Record the values and Pass/Fail result.
2. If applicable, please provide all alarm codes shown on the display (shown by scrolling to Display Screen #3). You can also read the alarms on a PC using Fox's FT4A View™ software. Please visit the following URL to download FT4A View™:

<https://www.foxthermal.com/products/pdf/ft4a/ft4a-view-setup.exe>
3. Test/Check the LED status (Heartbeat) light of the FT4A. Is the LED (green) blinking once per second?
 - The LED lights can be viewed by unscrewing the front cap to reveal the display and configuration panel. Then unscrew the two bottom screws holding the display. Swing open the display panel to reveal the wiring and LED lights (as shown in figure below).
 - The Heartbeat LED blinks fast when the FT4A is powered up, and blinks about once a second when the FT4A operates normally. The Transmit (yellow) and Receive LEDs (orange) blink when messages are sent and received through serial communication. The Receive LED (orange) may be illuminated if the FT4A has HART communication and the 4-20mA output is not connected.

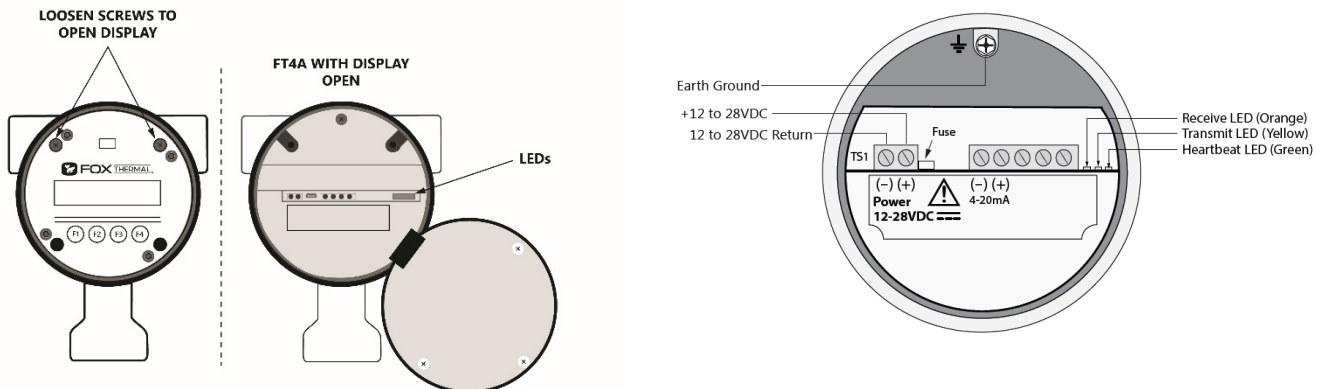

4. What is the measured input power to the flow meter at terminal TS1 pins 1 (+) and 2 (-)?
 - Acceptable voltages: 12 to 24VDC (10 to 30VDC full input power range)
5. Test/Check the fuse in the FT4A.
 - With the power off, take a resistance measurement across the fuse to ensure it is a short circuit.
 - Acceptable resistance: <1 ohm.

Section B: FT4A Measurement Accuracy and Calibration

6. Are the readings taken from the flow meter display or from a different source (PLC, DCS, etc)? The 4mA and 20mA scaling in the PLC or DCS must match the flow meter's settings. If you are using the 4-20mA output, also confirm that the measurement unit (SCFM, KG/HR, NM3H, etc.) in the Fox meter is the same as in your PLC/DCS.
7. If measuring a gas mixture, have you checked to be sure that the mixture parts equal 100%? If not, what gas are you currently measuring? Does the Gas-SelectX® setting in the FT1 closely match the composition of the gas being measured?
8. Check insertion depth, is the end of the sensor window 0.73" (18.5 mm) past the center line of the pipe?

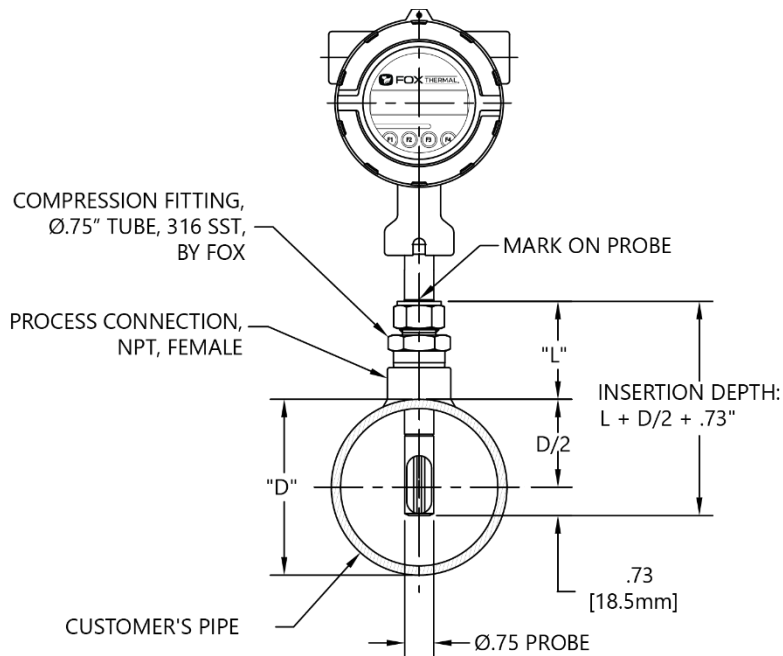

10. Check the direction of flow:
 - Is the flow direction indicator pointed in the direction of flow?
 - Is the flow direction indicator aligned with the pipe ± 2 degrees?
 - For inline type flow meters: Is the arrow on the flow body pointing in the direction of flow?

Model FT4X

Section A: FT4X Troubleshooting

Please refer to the troubleshooting section of the FT4X Manual. There is a link to the Fox model FT4X Instruction Manual located on the "Downloads" tab of the FT4X product webpage or here for quick reference:

<https://www.foxthermal.com/products/pdf/ft4x/ft4x-manual.pdf>

1. Perform a CAL-V™ test. Record the values and Pass/Fail result.
2. If applicable, please provide all alarm codes shown on the display (shown by scrolling to Display Screen #3). You can also read the alarms on a PC using Fox's FT4X View™ software. Please visit the following URL to download FT4X View™:

<https://www.foxthermal.com/products/pdf/ft4x/ft4x-view-setup.exe>

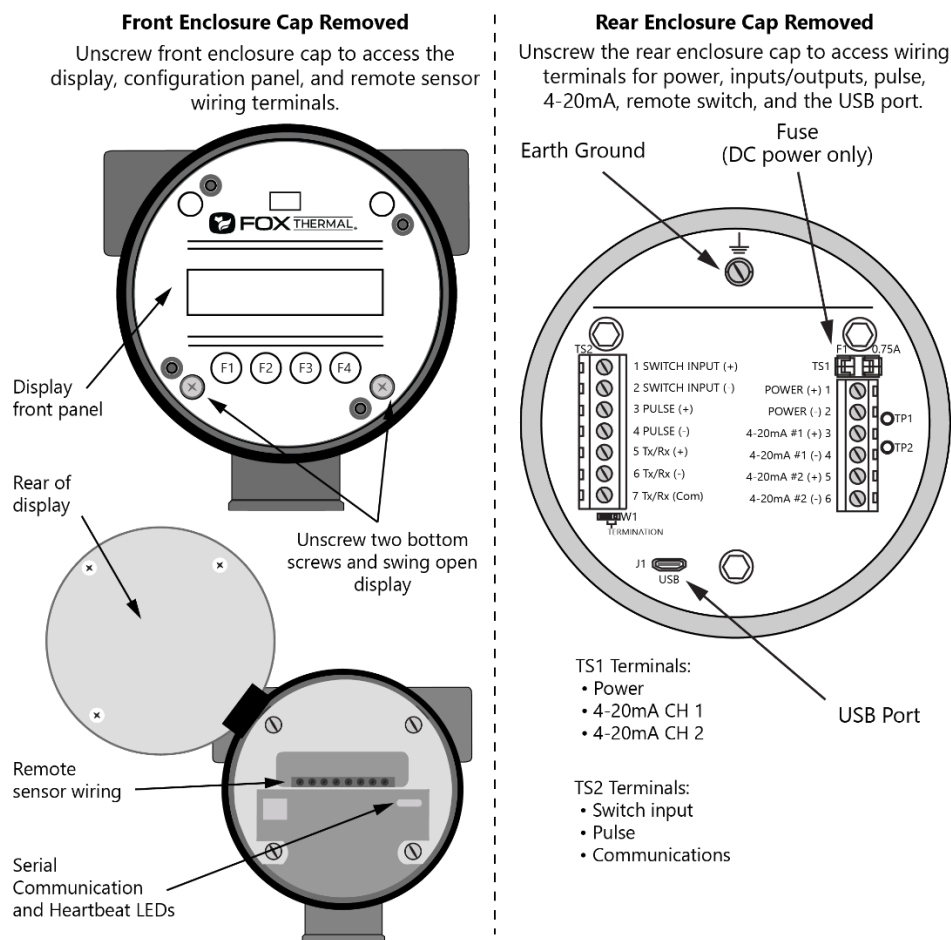

3. Open the rear enclosure cap. What is the measured input power to the flow meter at terminal TS1 pins 1 and 2?
 - Acceptable voltages:
 - DC powered: 12 to 24VDC, TS1 pin 1 (+) and pin 2 (-) (10 to 30VDC full input power range)
 - AC powered: 100 to 240VAC

4. For DC powered FT4X models, test/check the fuse (can be viewed by removing the rear enclosure cap).
 - With the power off, take a resistance measurement across the fuse to ensure it is a short circuit.
 - Acceptable resistance: <1 ohm.
5. Test/Check the LED status (Heartbeat) light of the FT4X. Is the LED (green) blinking once per second?
 - The LED light can be viewed by unscrewing the front cap to reveal the display and configuration panel. Then unscrew the two bottom screws on the display panel. Swing open the display panel to reveal the sensor wiring and LED lights. The LED status light is visible through the oval slot in the metal housing.
 - The Heartbeat LED blinks fast when the FT4X is powered up, and blinks about once a second when the FT4X operates normally. The Transmit (yellow) and Receive LEDs (orange) blink when messages are sent and received through serial communication. The Receive LED (orange) may be illuminated if the FT4X has HART communication and the 4-20mA output is not connected.
6. For remote sensor configurations (see image and table below):
 - If the sensor is remote from the electronics, please provide the length and gauge of the wire/cable connecting the sensor junction box to the electronics housing.
 - The serial number on the electronics housing must match the serial number on the probe/sensor assembly. It is a common mistake to mix the serial numbers when multiple meters with remote electronics are ordered. Please confirm the probe serial number is the same as on the electronics housing.
 - Check proper wire terminations at the sensor junction box and at the electronics housing (see table below).

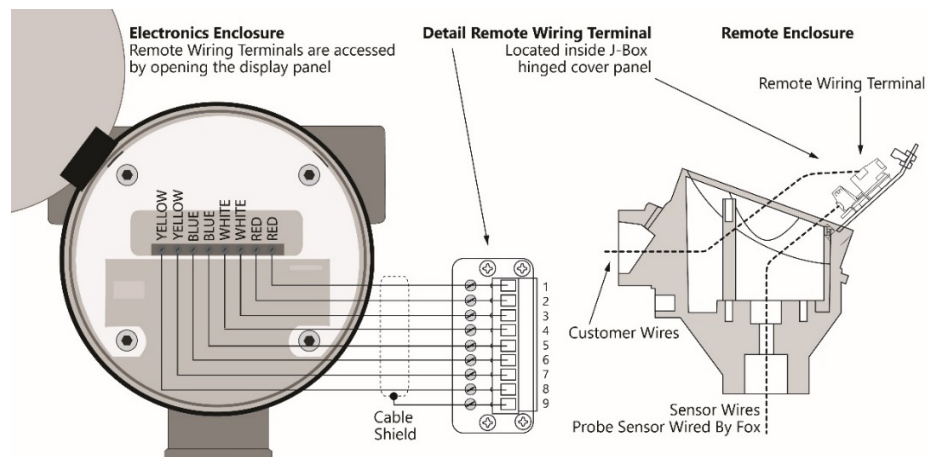

Electronics Enclosure Terminals	Extension Cable Wire Color	Remote Enclosure Terminal Numbers	Sensor Wire Color
Red	Red	1	Red
Red	Brown	2	Red
White	White	3	White
White	Black	4	White
Blue	Blue	5	Blue
Blue	Green	6	Blue
Yellow	Yellow	7	Yellow
Yellow	Orange	8	Yellow
No Connection	Shield	9	

Section B: FT4X Measurement Accuracy and Calibration

7. Are the readings taken from the flow meter display or from a different source (PLC, DCS, etc)? The 4mA and 20mA scaling in the PLC or DCS must match the flow meter's settings. If you are using the 4-20mA output, also confirm that the measurement unit (SCFM, KG/HR, NM3H, etc.) in the Fox meter is the same as in your PLC/DCS.
8. If measuring a gas mixture, have you checked to be sure that the mixture parts equal 100%? If not, what gas are you currently measuring? Does the Gas-SelectX® setting in the FT1 closely match the composition of the gas being measured?
9. Check insertion depth, is the end of the sensor window 0.73" (18.5 mm) past the center line of the pipe?

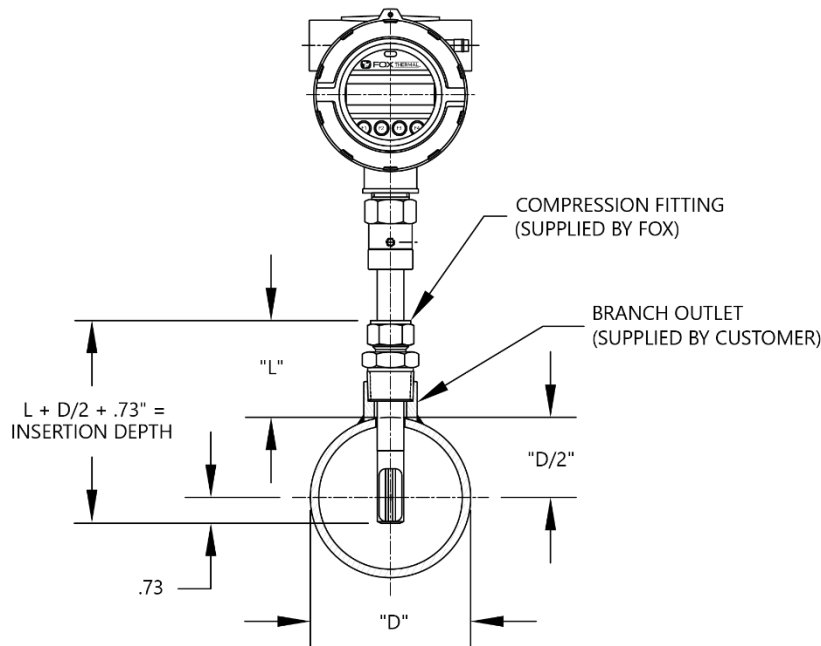

10. Check the direction of flow:
 - Is the flow direction indicator pointed in the direction of flow?
 - Is the flow direction indicator aligned with the pipe ± 2 degrees?
 - For inline type flow meters: Is the arrow on the flow body pointing in the direction of flow?